

Notes :

- All angles are made of aluminum anodised, dim:19x12x1,5.
- 2 angles not shown are installed respectively between : A & B et C & D.
- Base : alu. th. 1,5 à 2 mm anodised.

Coils for fields control. The distance between their axes is ajustable (oblong holes)

<p><b>Base (principle &amp; prototype)</b> Overview of the base and the floatting object</p>		<p><b>Flyingmagnet ©</b> Geometry #1a ©</p>
<p><b>Levitation of an object above a plane</b> Created and designed by R.Deroussent</p>	<p>Juin 2003 page 1 of 4</p>	



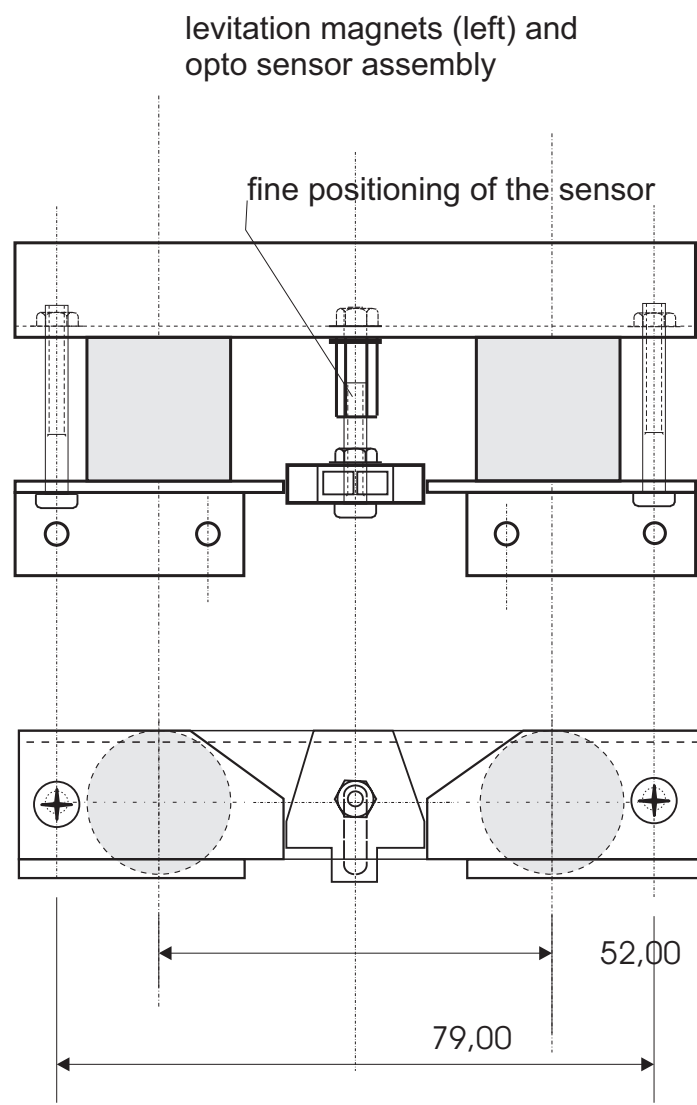
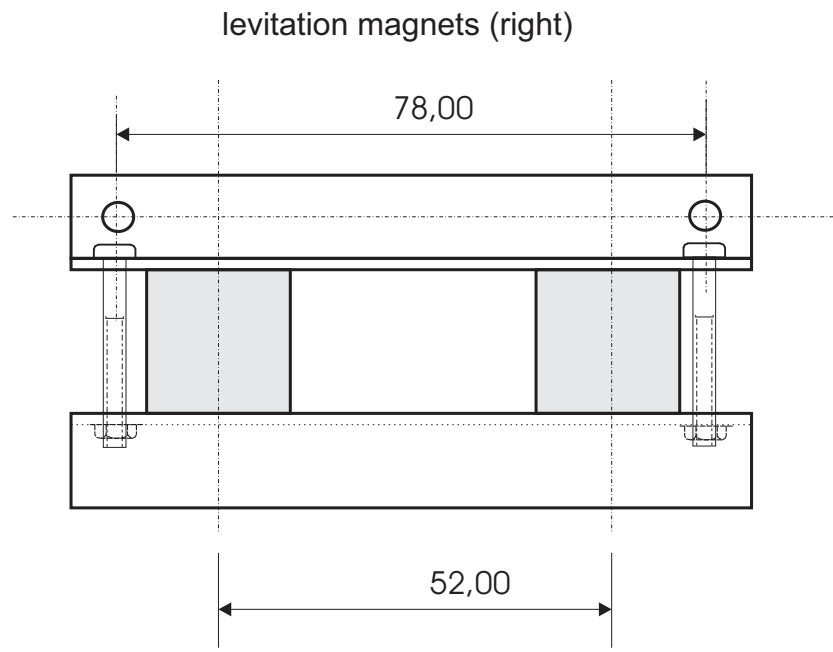

Notes : All fasteners must be non-magnetic (brass or stainless steel)  
 Angle aluminum 19x12,5 mm  
 the angle must be of 90° real  
 (Not angles for decoration)

<b>Calipers for adjustment and restraint of the levitation magnets.          Details of the opto sensor fine positioning device</b>		<b>Flyingmagnet ©</b> Geometry #1a, scale : 1
<b>Levitation of an object above a plane</b> Created and designed by R.Deroussent	Juin 2003 page 3 of 4	

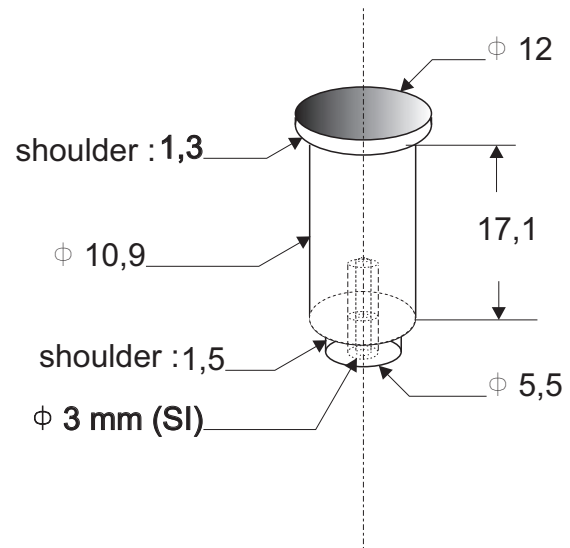

**Core :**  
 low remanence  
 soft iron material"

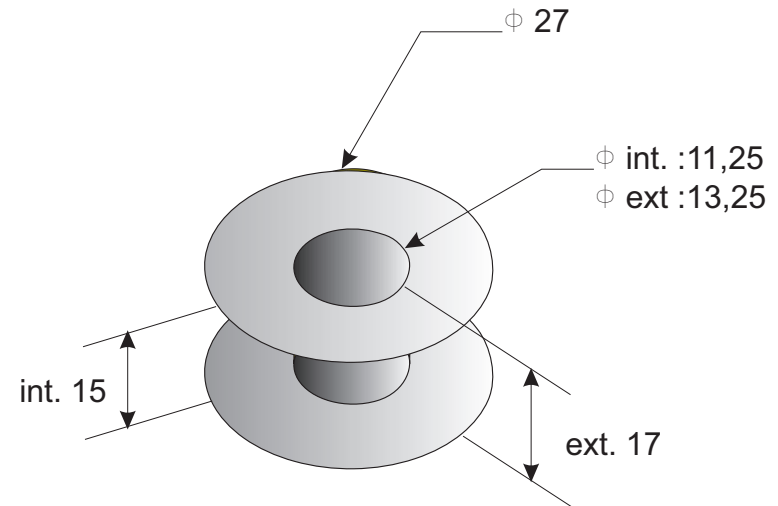

**Bobbin Form:**  
 (plastic or fiber, th.1 mm  
 )

**Winding:**  
 2700 tours  
 (36 layers of 75 tours)  
 copper wire  $\phi$ .015 mm  
 R : 160 Ohms (min.)

<b>Core, bobbin form and winding of coils for field control geometry #1 - (flyingmagnet)</b>		<b>Flyingmagnet ©</b> Apply to the geometry #1 to #4
<b>Levitation of an object above a plane</b> Created and designed by R.Deroussent	Juin 2003 page 4 of 4	